

PRODUCT INFORMATION PACKET

Model No: 445TTGN16588

Catalog No: U090A

150 HP Explosion Proof Motor, 3 phase, 1200 RPM, 460 V, 445T Frame, EPFC
Explosion Proof NEMA Motors



Regal and Marathon are trademarks of Regal Beloit Corporation or one of its affiliated companies.
©2020 Regal Beloit Corporation, All Rights Reserved. MC017097E

REGAL

Nameplate Specifications

Output HP	150 Hp	Output KW	112.0 kW
Frequency	60 Hz	Voltage	460 V
Current	181.0 A	Speed	1190 rpm
Service Factor	1.15	Phase	3
Efficiency	95.8 %	Power Factor	81
Duty	Continuous	Insulation Class	F
Design Code	B	KVA Code	G
Frame	445T	Enclosure	Explosion Proof Fan cooled
Thermal Protection	Thermostats (N/C)	Ambient Temperature	40 °C
Drive End Bearing Size	NU318	Opp Drive End Bearing Size	6316
UL	UL Listed And CSA Certified	CSA	Y
CE	N	IP Code	54
Hazardous Location	EXP PROOF CL I GR C&D CL II GR F&G T3B		

Technical Specifications

Electrical Type	Squirrel Cage Inverter Rated	Starting Method	Line Or Inverter
Poles	6	Rotation	Reversible
Resistance Main	.022 Ohms	Mounting	Rigid Base
Motor Orientation	Horizontal	Drive End Bearing	Roller
Opp Drive End Bearing	Ball	Frame Material	Cast Iron
Shaft Type	T	Overall Length	43.35 in
Frame Length	20.25 in	Shaft Diameter	3.375 in
Shaft Extension	8.75 in	Assembly/Box Mounting	F1 ONLY
Connection Drawing	A-EE7300S	Outline Drawing	B-SS515577-2025

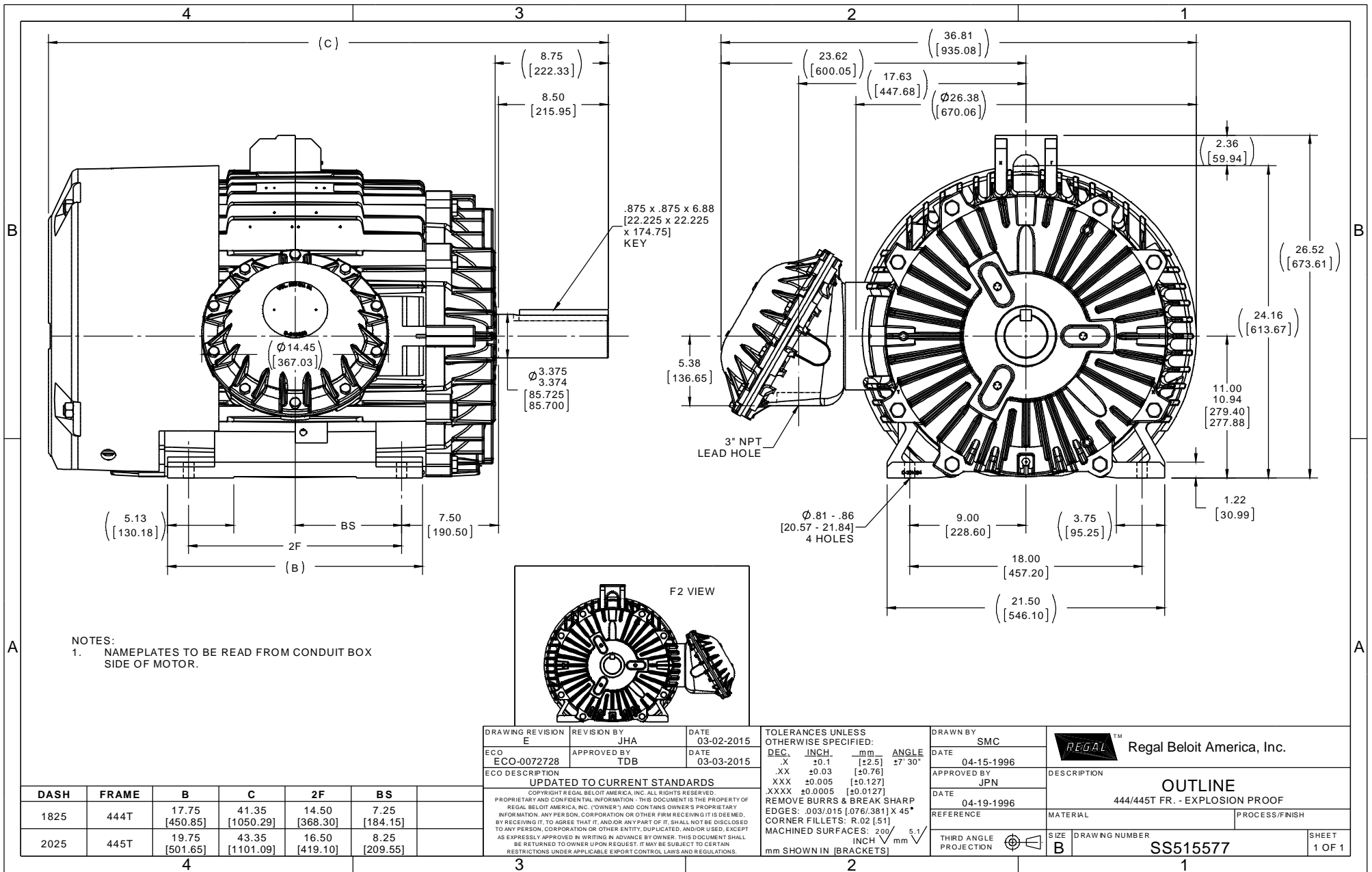

EE7300S

THREE PHASE – SINGLE VOLTAGE MOTOR

TO REVERSE ROTATION:
INTERCHANGE ANY TWO LINE
LEAD CONNECTIONS

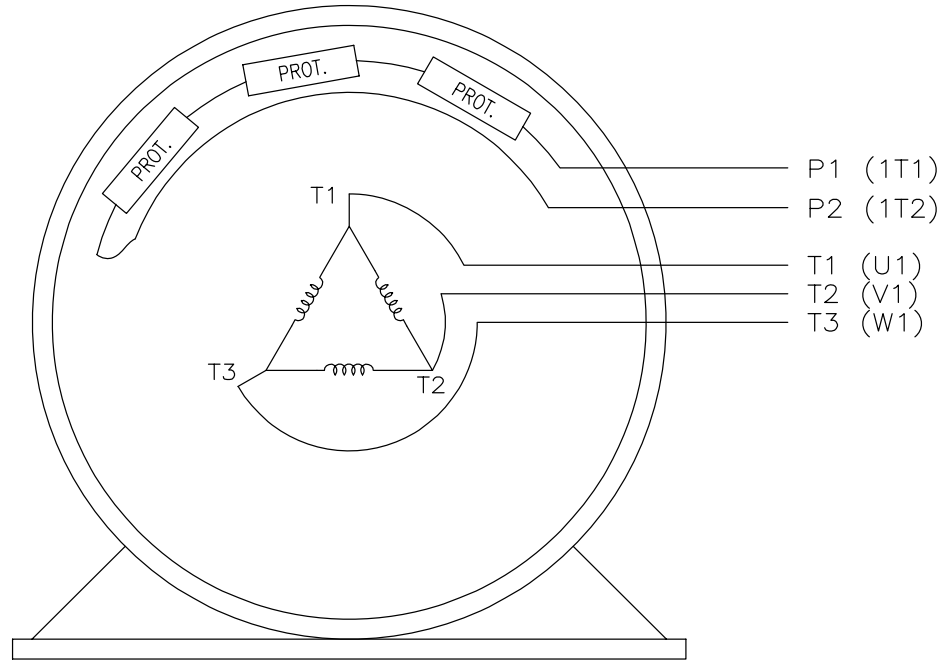

VIEW OF TERMINAL END

IF MOTOR HAS MULTIPLE
T'S PER LEAD CONNECT
TOGETHER LIKE T'S

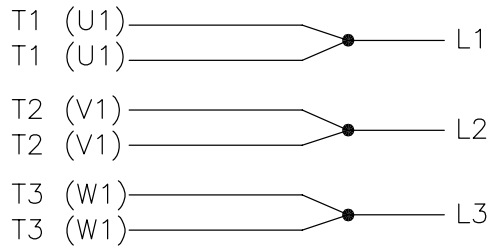

A-9806 DECAL

NO.	REVISION	BY & DATE	CHK	TOLERANCES UNLESS SPECIFIED		FINISH	DRAWN	PAGE	OF	REV.
				DEC.	INCHES					
F	UPDATED TITLE BLOCK	HV 02-27-2014	EWJ	.X	± -		KL	12-15-1999		
3	REMOVED "N.C." FROM PROT.'S MU61770	JJB 08-02-2010		.XX	± -		CHK	DJK 12-15-1999		
2	ADDED IEC MARKINGS MU61770	KL 09-16-2004	EAB	.XXX	± -	TITLE CONNECTION DIAGRAM – EXTERNAL SINGLE VOLTAGE 3Ø MOTOR	APPD	DJK 12-15-1999	SCALE	1=1
1	NEW DRAWING	KL 12-16-1999		.XXXX	± -	MAT'L.			REF	
				ANG	± -				FMF	
									PREV	
THIS DRAWING IN DESIGN AND DETAIL IS OUR PROPERTY AND MUST NOT BE USED EXCEPT IN CONNECTION WITH OUR WORK ALL RIGHTS OF DESIGN AND INVENTION ARE RESERVED THIS IS AN ELECTRONICALLY GENERATED DOCUMENT – DO NOT SCALE THIS PRINT						RFP	CAD FILE ee7300s		SIZE	DRAWING NO.
						DIST	WA-LB-SB	A	EE7300S	F



CERTIFICATION DATA SHEET

Model#: 445TTGN16588 AA **WINDING#:** T445692 NONE 4
CONN. DIAGRAM: A-EE7300S **ASSEMBLY:** F1 ONLY
OUTLINE: B-SS515577-2025

TYPICAL MOTOR PERFORMANCE DATA

HP	KW	SYNC. RPM	F.L. RPM	FRAME	ENCLOSURE	KVA CODE	DESIGN
150&125	112&93	1200	1190&985	445T	EPFC	G	B

PH	Hz	VOLTS	FL AMPS	START TYPE	DUTY	INSL	S.F	AMB°C	ELEVATION
3	60/50	460#380	181&180	LINE OR INVERTER	CONTINUOUS	F1	1.15/1.15	40	3300

FULL LOAD EFF: 95.8&95.4	3/4 LOAD EFF: 95.8	1/2 LOAD EFF: 95.4	GTD. EFF	ELEC. TYPE	NO LOAD AMPS
FULL LOAD PF: 81&82	3/4 LOAD PF: 77	1/2 LOAD PF: 67.5	95.4	SQ CAGE INV RATED	72

F.L. TORQUE	LOCKED ROTOR AMPS	L.R. TORQUE	B.D. TORQUE	F.L. RISE°C
662 LB-FT	1085	1075 LB-FT 162	1700 LB-FT 257	65

SOUND PRESSURE @ 3 FT.	SOUND POWER	ROTOR WK^2	MAX. WK^2	SAFE STALL TIME	STARTS /HOUR	APPROX. MOTOR WGT
72 dBA	82 dBA	91 LB-FT^2	2350 LB-FT^2	25 SEC.	2	2550 LBS.

***** SUPPLEMENTAL INFORMATION *****

DE BRACKET TYPE	ODE BRACKET TYPE	MOUNT TYPE	ORIENTATION	SEVERE DUTY	HAZARDOUS LOCATION	DRIP COVER	SCREENS	PAINT
STANDARD	STANDARD	RIGID	HORIZONTAL	PREMIUM SEVERE DUTY	EXP PROOF CL I GR C&D CL II GR F&G T3B	FALSE	NONE	BLUE (EPOXY)

BEARINGS		GREASE	SHAFT TYPE	SPECIAL DE	SPECIAL ODE	SHAFT MATERIAL	FRAME MATERIAL
DE	OPE						
ROLLER	BALL	POLYREX EM	T	NONE	NONE	1045 HOT ROLLED (C-204)	CAST IRON
NU318	6316						

THERMO-PROTECTORS				THERMISTORS	CONTROL	SPACE /n HEATERS
THERMOSTATS	PROTECTORS	WDG RTDs	BRG RTDs			
TSTATS (N/C)	NOT	NONE	NONE	NONE	FALSE	NONE VOLTS

If Inverter equals NONE, contact factory for further information

INVERTER TORQUE: CONSTANT 10:1
INV. HP SPEED RANGE: NONE
ENCODER: NONE
NONE NONE
NONE NONE PPR
BRAKE: NONE NONE
NONE P/N NONE
NONE NONE
NONE FT-LB NONE V NONE Hz

*
N
O
T
E
S
*

DATE: 06/21/2017 06:09:18 AM
 FORM 3531 REV.3 02/07/99

** Subject to change without notice.

